

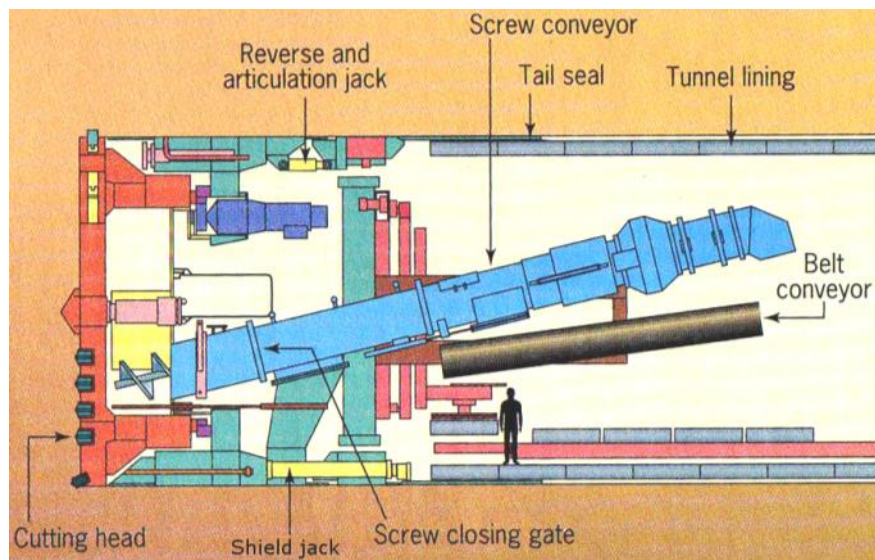

20 November

Medway
existing high-

Viaduct adjacent to two ex-
way bridges (see page 6)



Contents

- 2 Notices
- 2 SIHG Meetings
- 3 Venues, Times & Contacts
- 4 Sock-Knitting Frames by Glenys Crocker
- 7 Exhibitions, Conferences
- 8 The Planning and Construction of High Speed 1
by Doug Irvine report by Mike Davison
- 9 News from Brooklands 2018
- 9 Regular Events 2018
- 10 Diary May, June, July 2018
- 13 Surrey Industrial History Group Officers
- 14 SIHG Annual General Meeting Notice

SIHG Newsletter No 218 May 2018

Enquires to Programme Co-ordinator Bob Bryson: 01483 577809, meetings@sihg.org.uk.

**The 43rd season of SIHG
Industrial Archaeology Lectures at Guildford**
alternate Mondays or Tuesdays, 19:30-21:30
Church House Guildford, 20 Alan Turing Road, Guildford GU2 7YF
(map: www.sihg.org.uk).
Single lectures at £5, payable on the night, are open to all.

2018

Mon 1 Oct **Brunel, Scott Russell and the Great Eastern**
Prof. Andrew Lambert, Dept of War Studies King's College London

Tue 9 Oct **London Underground's Edwardian Tile Patterns**
Douglas Rose, London historian and information designer

Tue 23 Oct **R34: New York - There & Back Again - an Airship's tale** Nigel Hills, of the Airship Association

Mon 5 Nov **A History of the Singer Marke** Michael Hyman, Editor MASCOT for the Assn of Singer Car Owners

Mon 19 Nov **The Joe Lyons Story: Food for Thought** Neville Lyons, relative of the co-founder of J Lyons & Co

Tue 11 Dec **Members' Talks Evening - Free to all** Short talks by members plus refreshments

2019

Mon 7 Jan **The Ramblings of a Railwayman** Geoff Burch, railwayman & author

Tue 22 Jan **A History of the Post Office Underground Railway**
Chris Taft, Historian and Head of Collections at The Postal Museum

Tue 5 Feb **Conkers, Cordite and the Birth of Modern Biotechnology**
Martin Adams, Emeritus Prof of Microbiology, University of Surrey

Tue 19 Feb **TBA**

Tue 5 Mar **Iron Men - C19th Engineer Henry Maudslay and his Circle**
David Waller, author and former Financial Times journalist

Thursday Morning Lectures at Leatherhead, weekly 10:00-12:00

Room G6 The Institute, 67 High Street Leatherhead KT22 8AH
Non-member full fee £50 SIHG member £45.
Single lectures at £5, payable on the night, are open to all.

2018

Thu 4 Oct **The Merchant Navy at War Pt III, including The Falklands** Richard Mellor, Maritime Shipping Rtd
** Details of further meetings to follow **

Surrey Industrial History Group

Saturday 28 July 2pm

AGM and Conservation Award Ceremony

at Shere Village Hall and Museum;
see pages 14 & 15 for details.

(An up-to-date agenda will be available on the day.)

A **SIHG Membership Renewal Form** is enclosed.

Please complete it promptly and send it,
with a cheque payable to 'Surrey Archaeological Society', to
Surrey Archaeological Society (SIHG), Castle Arch, Guildford GU1 3SX.
You may also choose to pay by Standing Order.
If you already pay by Standing Order you need not take any action..

The programme for the **SIHG Guildford Lectures**
for Autumn 2018 and Spring 2019 is on page 2.

Please note that cheques should be made out to 'SIHG' and
sent to Bob Bryson, 6 Wychelm Rise, Guildford, Surrey GU1 3TH

Please note the NEW VENUE for the Guildford meetings -
Church House Guildford,
20 Alan Turing Road, Guildford GU2 7YF
(on the Science Park)

Venues, Times & Contacts

Most venues open 30 minute before the published time.

- Amberley Museum & Heritage Centre:** 10:00-17:00; £14/£13; Amberley Railway Station BN18 9L; www.amberleymuseum.co.uk; 01798 831370.
- Ancient Technology Centre:** 10:00-16:00; £6; Damerham Road, Cranborne, Dorset BH21 5RP; (behind school); 01725 517618, www.ancienttechnologycentre.co.uk.
- Anne of Cleves House:** Tue-Sat 10:00-16:00, Sun-Mon 10:00-17:00; £6:10/£5:80; 52 Southover High Street, Lewes, Sussex BN7 1JA; 01273 474610.
- Berkshire Industrial Archaeology Group (BIAG):** 19:30; £2-50; St Mary's Church Hall, Castle Street, Reading, RG1 7RD; www.biag.org.uk.
- Brooklands:** open Summer 10:00-17:00, Winter 10:00-16:00; £11/£9.90; Brooklands Rd, Weybridge, Surrey KT13 0QN; www.brooklandsmuseum.com; 01932 857381.
- Brunel Museum:** Railway Avenue, Rotherhithe, London SE16 4LF; £6/£4; 020 7231 3840.
- Bursledon Brickworks:** steam days £7/£6, open days £4/£3; Coal Park Lane, Swanwick, Southampton SO31 7GW; www.bursledonbrickworks.org.uk; 01489 576248.
- Chatham Historic Dockyard:** 10:00-18:00, £22/£19-50; Chatham, Kent ME4 4TZ; 01634 823800, www.thedockyard.co.uk.
- Crofton Beam Engines :** 10:30-17:00; £8/£7; Crofton, Marlborough, Wiltshire SN8 3DW
- Crossness Engines:** 10:30-16:00, £8; The Old Works, Crossness STW, Belvedere Road, Abbey Wood, London SE2 9AQ; www.crossness.org.uk; 020 8311 3711.
- Croydon Airport Society Visitor Centre :** open 1st Sunday of the month, 11:00-16:00, free; Airport House, Purley Way, Croydon CR0 0XZ.
- Croydon Natural History & Scientific Society (CNHSS):** 19:45; free? UR Church Hall, Addiscombe Grove, E Croydon CR0 5LP; <http://cnhss.co.uk>; 0208 668 1431.
- Didcot Railway Centre:** 10:30-17:00; £10-00/£9-50; Didcot Parkway railway station, Didcot, Oxfordshire OX11 7NJ; www.didcotrailwaycentre.org.uk; 01235-817200.
- Docklands History Group:** 18:00, £2; Museum of London Docklands, No 1 Warehouse, West India Quay, Hertsmere Rd, Canary Wharf, London E14 4AL; www.docklandshistorygroup.org.uk; 01689 851982.
- Dorking Museum & Heritage Centre:** Thurs, Fri, Sat 10:00-16:00; £2/£1; 62 West Street, Dorking, Surrey RH4 1BS; www.dorkingmuseum.org.uk, 01306 876 591.
- Gatwick Aviation Museum:** Open Friday, Saturday and Sundays; 09:30-15:30; £7-50; Vallance-Byways, Lowfield Heath Road, Charlwood RH6 0BT; <http://www.gatwick-aviation-museum.co.uk/>; 01293 862417.
- Greater London Industrial History Society (GLIAS):** 18:00; The Gallery, Alan Baxter Associates, 75 Cowcross Street (through the archway and in the basement at the rear of the building), Farringdon, EC1; info Tim Sidaway, secretary@glias.org.uk; www.glias.org.uk.
- Greenwich Industrial History Society:** 19:30, £1; Old Bakehouse, rear of Age Exchange Centre, opp Blackheath Stn, Bennett Park, 11 Blackheath Village SE3 9LA; no parking; <http://greenwichindustrialhistory.blogspot.com>.
- Hampshire Industrial Archaeology Society (HIAS):** 19:45, free; Underhill Centre, St. John's Road, Hedge End, Hants SO30 4AF; www.hias.org.uk; 01962 855200.
- Honeywood Museum Friends:** 19:30, £5.0; www.friendsofhoneywood.co.uk.
- Honeywood Museum:** open Wed-Fri 11:00-17:00, Sat-Sun, BH Mon 10:00-17:00, free; .Honeywood Walk, Carshalton SM6 3NX.
- Inland Waterways Association (IWA):** £10/£8; no prior booking required; www.waterways.org.uk; 0203 612 9624.
- Kempton Steam Museum:** 10:30-16:00, £7/£6; Snakey Lane, off elevated section of A316, Hanworth, Middx; entrance TW13 7ND; www.kemptonsteam.org; 01932 765328.
- Kirkaldy Testing Museum:** First Sunday of Every Month 11:00-17:00; £5/£4; 99 Southwark Street, London SE1 0JF; www.testingmuseum.org.uk/.
- Lambeth Local History Forum:** www.lambethlocalhistoryforum.org.uk/.
- Leatherhead & District Local History Society (LDLHS):** meetings 20:00; £2; The Institute, 67 High Street, Leatherhead KT22 8AH; www.leatherheadlocalhistory.org.uk.
Leatherhead Museum: Hampton Cottage, 64 Church Street, Leatherhead, Surrey, KT22 8DP; 01372 386348.
- London Bus Museum:** see Brooklands.
- London Canal Museum:** Open 10:00-16:30; Talks 19:30, £4/£3; 12/13 New Wharf Road, London N1 9RT; www.canalmuseum.org.uk; 0207 713 0836.
- London Museum of Water and Steam:** Green Dragon Lane, Brentford, Middx TW8 0EN; www.waterandsteam.org.uk; 020 8568 4757.
- Loughton & District Historical Society:** Methodist Church, Loughton High Road; 20:00 2nd Thursday of the month, visitors welcome, £2.50; www.loughtonhistoricalsociety.org.uk.
- Lowfield Heath Windmill:** (14:00-17:00?), free/donation; Russ Hill, Charlwood RH6 0EL (TQ 235 408). www.lowfieldheathwindmill.co.uk/, 01403 272664.
- Mapledurham, Watermill:** tour £10, cream tea £6.50; Tues, Weds, Thurs afternoons; Mapledurham, Reading RG4 7TR; www.mapledurhamwatermill.co.uk; mill and tearoom open for pre-booked guided tours only 07843 742833, enquiries@mapledurhamwatermill.co.uk
- Museum of London Docklands:** Mon-Sun: 10:00-18:00; no.1 Warehouse, West India Quay, London E14 4AL; www.museumoflondon.org.uk/docklands, info.docklands@museumoflondon.org.uk, 020 7001 9844.
- Newcomen Society Birmingham:** Thinktank, (Birmingham Science Museum), Millennium Point, Aston University, Curzon Street, Birmingham, W Midlands B4 7XG
- Newcomen Society London:** 17:45, free; <http://newcomen.com>; new venue - The Dana Studio, The Dana Centre, 165 Queens Gate, London SW7 5HD.
- Newcomen Society Portsmouth:** 18:30; free; Portland Building, University of Portsmouth, Saint James's Street, ~Portsmouth PO1; <http://newcomen.com>.
- Postal Museum:** 15-20 Phoenix Place, London WC1X 0DA; open 10:00-17:00; exhibition only £11/£9; exhibition + Mail Rail ride £17.05/£15.40 (booking advised); www.postalmuseum.org, 0300 0300 700.
- Portsmouth Historic Dockyard :** 10:00-17:30, site ticket, annual £28/£26; HM Naval Base, Portsmouth PO1 3LJ; www.historicdockyard.co.uk; 02392 728060.
- Railway and Canal Historical Society :**18:30, free? The Rugby Tavern, Rugby Street, London WC1N 3ES; www.rchs.org.uk.
- Royal Gunpowder Mills Waltham Abbey:** 10:00-17:00; school holidays; £10.50/£9; Beaulieu Drive, Waltham Abbey, Essex EN9 1JY, 01992 707 350.
- Rural Life Centre:** open Summer Wed-Sun 10:00-17:00 + Bank Holiday Mondays, Winter Wed/Sun 10:00-16:00; £8-50/£7-50; Old Kiln Museum, Reeds Road, Tilford, Farnham, Sy GU10 2DL; www.rural-life.org.uk; 01252 795571.
- STEAM - Museum of the Great Western Railway:** 10:00-16:00, £8/£6-50; Kemble Drive, Swindon SN2 2TA; www.steam-museum.org.uk; 01793 466 646.
- Subterranea Britannica:** www.subbrit.org.uk.
- Sussex Industrial Archaeological Society (SIAS) :** www.sussexias.co.uk.
- Wandle Industrial Museum:** £0.50; Wednesdays 13:00-16:00, Sundays 14:00-17:00; The Vestry Hall Annexe, London Road, Mitcham , CR4 3UD; no parking; 020 8648 0127, www.wandle.org/.
- Watercress Line, Mid Hants Railway:** all day travel £14, free on non-running days; Station Rd, Alresford, Hants SO24 9JG; (or Station Rd, Alton, Hants GU34 2PZ); www.watercressline.co.uk; 01962 733810.
- Weald & Downland Living Museum,** £13/£12; Summer 10:30-18:00; Singleton, Chichester, West Sussex PO18 0EU; www.wealddown.co.uk; 01243 811348.
- Wey & Arun Canal Trust:** The Granary, Fritchfold Farm, Loxwood, Billingshurst W Sussex, RH14 0RH; office@weyandarun.co.uk; 01403 752403; (Mon - Fri 09:30-13:30)

Sock-Knitting Frames

by Glenys Crocker

SOCK-KNITTING REPORT 1986 – 2017 (with a long gap)

SIHG, the Association for Industrial Archaeology,
Godalming Museum,
East Midlands links, the Stocking Frame,
the Circular Sock Machine,
Horatio Herbert Kitchener & the Vintage Krankers

The extended title was on the first slide of my presentation at the *SIHG members' evening on 12 December 2017*.

In 1986 the Association for Industrial Archaeology held its annual conference at Loughborough University. Some members of SIHG attended the weekend conference and the coach trips in the following week. We were reminded of the early framework knitting industry around Godalming and its survival, first by specialising in fleecy underwear and later in high quality outerwear, which continued through most of the twentieth century.

At the time, plans were underway in the East Midlands to commemorate the 400th anniversary of the invention of the stocking frame by William Lee in 1589 and we decided to mark the occasion in Surrey. Godalming Museum liaised with our contacts in Leicester and Nottingham to organise a series of events in 1989.

The museum organised a 'Wool Year' of displays and activities and designed a town trail around associated sites and surviving buildings. The museum's stocking frame was restored to a semblance of working order in 1988 by a technical expert from Ruddington Framework Knitters Museum near Nottingham. SIHG arranged for Marilyn Palmer, President of the AIA and author of the Shire Album on framework knitting, to give a talk in the 1988-9 lecture series at the University of Surrey, and to host a residential week-end at Loughborough University in April 1989. Members of SIHG and Friends of Godalming Museum were joined by members of the West Surrey Guild of Spinners, Weavers and Dyers and a few other interested individuals.

See page 8 for photos of the meeting

I undertook to research the history of the industry in the Godalming area, including recording relevant buildings. Documentary sources were found in Godalming Museum and the Surrey History Centre and also in libraries and record offices in London and Nottingham. I wrote up my work in two main publications:

'The Godalming knitting industry and its workplaces', *Industrial Archaeology Review*, vol.14 no.1 (Autumn 1991), pp 33-54

'The place of Godalming in the hosiery and knitwear industry: history and products', *Surrey Archaeological Collections*, vol.81 (1991-2), pages 41-70

Knitting Machines

Godalming Museum's stocking frame was presented to the Borough in 1936 by Allen Solly & Co. of Arnold, Nottingham, who had a factory in Godalming from 1860 to 1888. It made four stockings at once, seen hanging on the needles in the photograph (right).

The treadles at the base operate cords on the large pulley wheel which move a runner called a **slurcock**. This slides along a track, releasing shaped metal plates called **jack sinkers** one by one so that they fall and push the knitting yarn down between pairs of needles, forming loops. A second set of sinkers, the **lead sinkers** (set in lead) are brought down all at once to divide the loops

and equalise them. A presser bar is brought down to close the needles, which are of the open, or **bearded** type (page 6). Then the needles are moved back, drawing the yarn through the loops of the previous row of knitting. The result is a flat piece of knitting which has to be seamed to form a garment.

Circular knitting machines with latch needles (see page 6), which made stockings in the round, were introduced in the mid-nineteenth century. They were small and suitable for domestic use and small-scale production in institutions, including those that employed disabled people. Manufacturers of the machines included Fosters of Preston, Griswold of Leicester and Harrisons of Manchester. Large numbers of machines were manufactured in the First World War to supply socks to the troops.

The importance of socks in the First World War

During the war, knitters were called upon to knit for the war effort and were provided with sock machines on condition that they made at least 30 pairs of socks. Socks made by machine had to be joined up at the toe

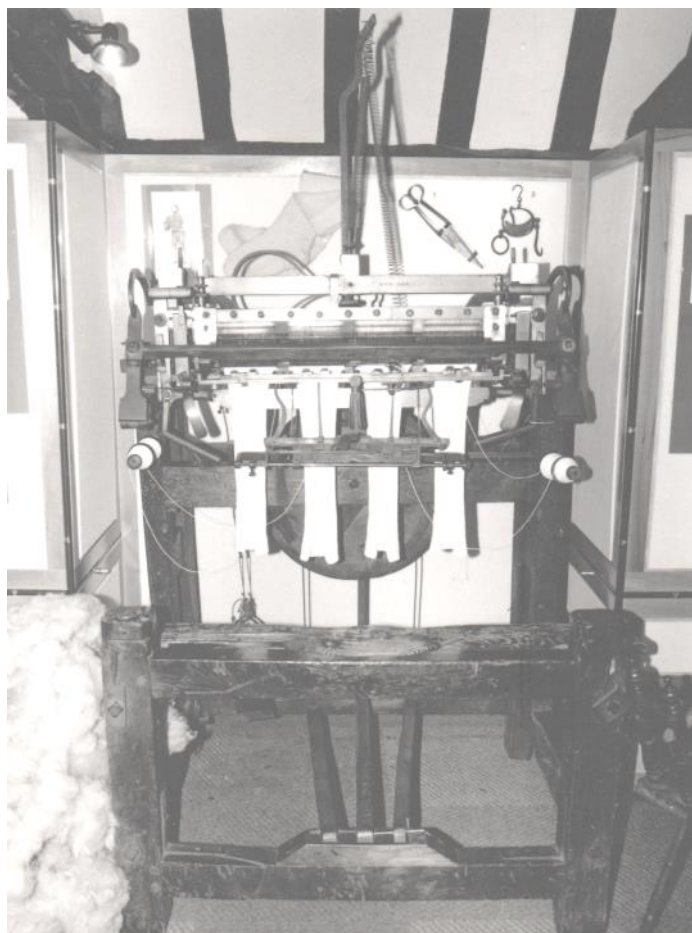

and this was generally done with a hand-sewn seam. The seams caused chafing of the skin and blisters that were open to bacterial infection in the conditions in the trenches. This caused the extremely unpleasant condition known as ‘trench foot’, which resulted in many amputations. As Secretary of State for War, Kitchener organised a system of ensuring regular and frequent supplies of clean dry socks. Knitters were ordered not to finish socks with sewn seams but to join the toes by grafting, which seamlessly reproduces the structure of knitting. Some modern knitting manuals still refer to grafting as Kitchener Stitch (below).

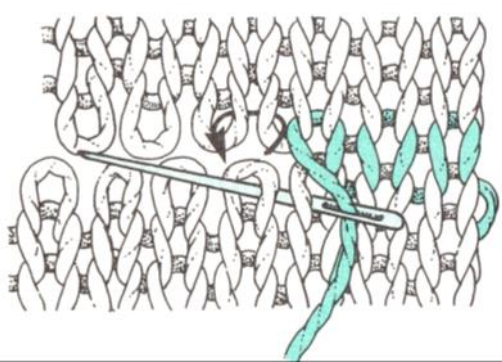

The conservation of sock machines

Circular sock machines were beginning to be collected and restored at the time of our visit to the East Midlands in 1989. Ruddington Framework Knitters Museum and the Wigston Framework Knitters Museum near Leicester both had substantial collections, including machines maintained in working order and in use. Some machines were owned, maintained and used by individual craft knitters such as Louise Lee, who used to demonstrate at the Rural Life Centre (formerly the Old Kiln Museum) at Tilford near Farnham. The photograph (right) shows her knitting there in 1984, dressed in period costume. She continued to demonstrate at Rustic Sunday, an annual event held on the last Sunday in July, for many years, and bequeathed the machine to the museum in her will.



In the 1989 Wool Year, an appeal for circular sock machines for Godalming Museum produced three. These were restored to working order and demonstrated at several public events. Not all could be housed at the museum so two of them remained in my care, and came to be side-lined as other interests and responsibilities

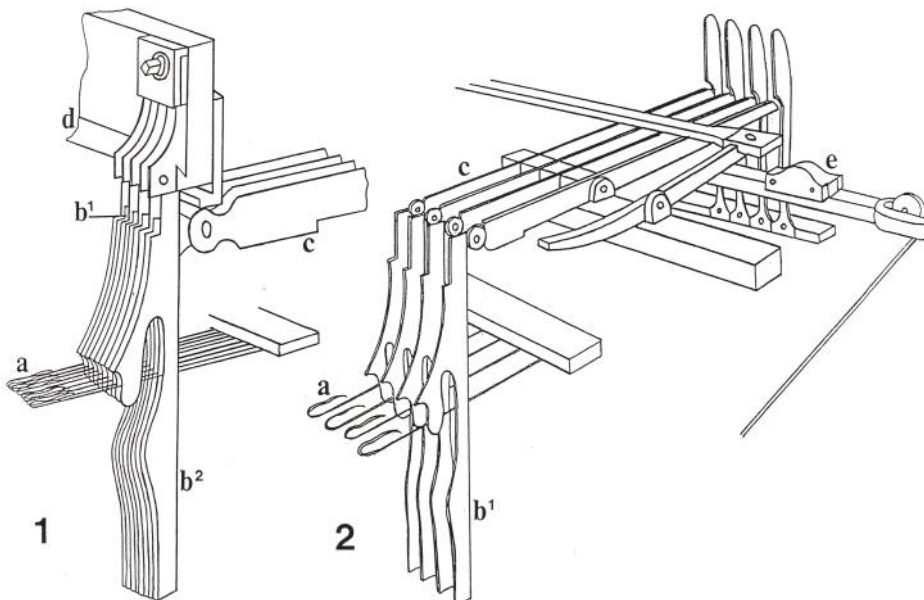
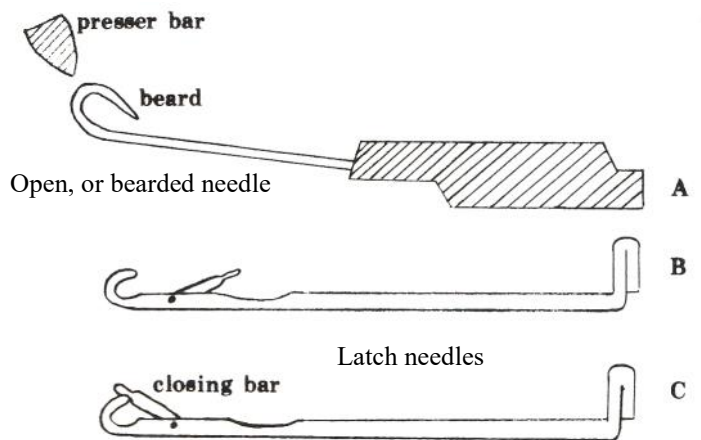

arose. However, my recent presentation prompted me to raise the matter with Godalming Museum. This turned out to be a timely move because the museum is refurbishing its knitting gallery with expert technical help from a former employee in the industry. (Watch this space.)

Meanwhile since 1989 interest in the old sock machines has greatly increased, along with enthusiasm for the creative knitting and wearing of socks among craftspeople. In Britain a society of enthusiasts, who collect, restore and operate old machines, is named The Vintage Krankers. This is a reference to the basic mechanism of turning a handle and causing the latch needles to rise in grooves around a cylinder, grab the yarn and then fall,

drawing it through the loops of the previous round.

Examples of prices of antique machines advertised on-line in November 2017 included £350, £918, £958 and £1,350. Internationally the Circular Sock Machine Society, which originated in the USA in 2000 had 300 members in 2017 from the USA, UK, South Africa, Japan, Australia, Switzerland, Canada and New Zealand. Also in the USA, the Erlbacher Gearhart Knitting Machine Company (originally a manufacturer of parts for racing cars which diversified) makes new machines at Cape Girardeau, Missouri. A de-luxe model is priced at (\$1,899).

Thanks are due to Dr Hilary Kent, MOD scientist and Vintage Kranker, for information about circular sock machines in the First World War. With other members of the West Surrey Guild, she demonstrates Louise Lee's sock machine at the Old Kiln Museum on Rustic Sundays and other occasions. ☐



Socks



Dr Hilary Kent, MOD scientist and Vintage Kranker, demonstrates Louise Lee's sock machine at the Old Kiln Museum

Circular sock machine





Marilyn Palmer and Peter Neaverson of the Leicestershire Industrial History Society with members of the party at Ruddington Framework Knitters' Museum near Nottingham.

Exhibitions 2018
until 3 June Museum of English Rural Life: CARNEVALE: Objects Designed for Pigs play objects which appeal to both humans and pigs by Andrea Roe; exhibition including films.
until 10 June Portsmouth Historic Dockyard: Shipyard paintings of the BAE shipyards on the Clyde and Forth by Lachlan Goudie.
until 16 June Guildford Museum Tunsgate: A Century of Change - exhibition.
until 17 June Chatham Historic Dockyard: Interactions with Artists <i>Powerful Tides: 400 Years of Chatham and the Sea</i> £24.00/ £21.50 (Discounts online)
to 13 July STEAM: KGV - A Locomotive Legend.
until 9 Sept Museum of London Docklands: From Slavery to Military Service Fighting for Empire - in the West India Regiments.

Conferences 2018
Docklands History Group All Day Conference Saturday 12 May Shipbuilding on the Thames 09:45–17:25 Weston Theatre of the Museum of London Details & booking: www.docklandshistorygroup.org.uk/
Association for Industrial Archaeology Spring Tour – Saxony Monday 14 - Sunday 20 May details from Bill Barksfield, Heritage of Industry Ltd, The Gables, 20 Main Road, East Hagbourne, Oxon OX11 9LN; 01235 352275, bill@heritageofindustry.co.uk , www.heritageofindustry.co.uk .
Country House Comfort & Convenience - East Yorkshire Monday 4 - Friday 8 June - details from Bill Barksfield, as above.
Portsmouth Historic Dockyard - Conference Friday 15 - Saturday 16 June; 10:00-16:00; Silent and Secret - 50th Anniversary of HMS Resolution, first Polaris; at Royal Navy Submarine Museum; contact george.malcolmson@nmrn.org.uk .
Railway and Canal Historical Society (+ RCHS): Thursday 21 - Sunday 24 June 2nd International Early Main Line Railways Conference at National Railway Museum, York; info www.rchs.org.uk .
Brewery History Society AGM Saturday 30 June at Harvey's Brewery, Cliffe High St, Lewes, Sussex BN7 2AH; 11:00 for 12:00. Plus tour of a nearby microbrewery on Friday 29 June, and a walking tour of Lewes on Sunday 1 July. Please email visits@breweryhistory.com for tours or walk.
Newcomen Society: Annual Conference & Tour Teesside; at Middlesborough; Friday 13 09:00 - Tuesday 17 18:00 July.

SIHG Lecture - 30th January 2018
The Planning and Construction of High Speed 1
by Doug Irvine, Civil Engineer
report by Mike Davison

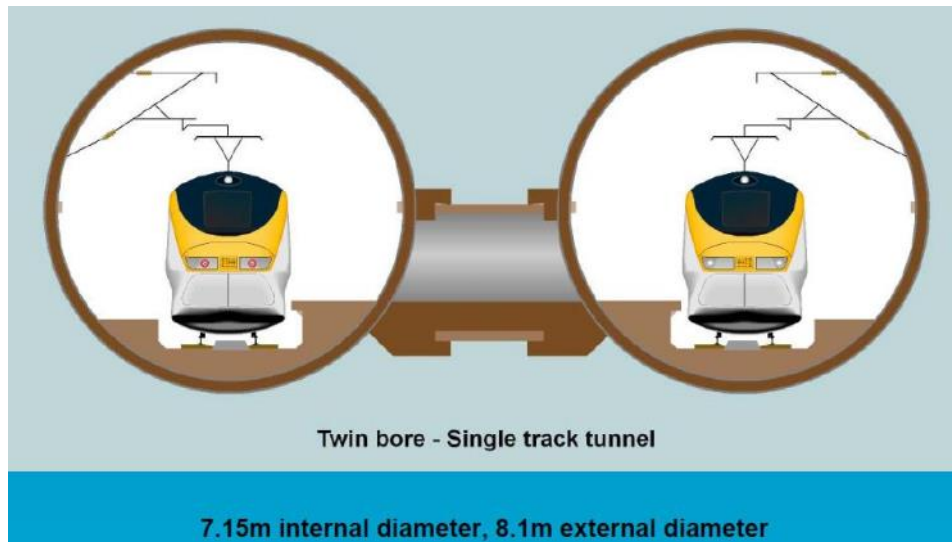

The High Speed 1 line links St Pancras Station to the Channel Tunnel terminal and was the first brand new railway to be built in the UK for a hundred years. With a total length is 67 miles including 17 miles in tunnels, it is designed for a maximum speed of 300 km/h. Designed for both passengers and freight, it was built on time and to budget.

Doug Irvine explained that he would divide his talk into three sections, namely:

1. Evolution & Planning
2. Aspects of Construction
3. Archaeology & Heritage.

Evolution & Planning

The main milestones were as follows. In 1971 British Rail and SNCF produced a scheme for a London-Paris link. In 1987 the Channel Tunnel Act was passed. It was assumed at this stage that in UK the existing domestic track would be used between London and the coast, the idea of having a separate High Speed link initially getting a hostile reception. By 1990 the digging of the tunnel had been completed, meanwhile in France they were already building a High Speed link to Paris. In 1991 a new BR report was issued showing possible routes for an 'eastern' High Speed link which, among other things, would provide for the regeneration of parts of East London. 1996 saw the passing of the Rail Link Act, and the contract for this work was awarded to London & Continental Railway.

In 1998 project funding was re-structured and this included financial support by both the Government and Railtrack. In the same year construction of the link got under way. In 2001 Railtrack went into receivership and in 2002 Network Rail was set up as a public body. In 2010 the Government sold its stake to a Canadian company but by this time, in 2007, the link had been completed and trains were running. The foregoing lists only the bare bones of events but, as can be seen, the project had a somewhat convoluted beginning.

Aspects of Construction

The section of line from St Pancras to Dagenham is nearly all in tunnel. This was all soft ground tunnelling, the cross-section being twin bores of 7.15m diameter with cross passages. For this tunnelling operation Tunnel Boring Machines (TBMs) were used. A TBM is a giant machine with a rotating cutting head. A screw conveyor picks up the spoil, this being disposed of by means of a conveyor. When a section of tunnel has been excavated precast concrete lining segments are brought up to the face and installed to form a ring. The segments are reinforced with steel fibres to prevent damage during handling. Jacks are then used to push the TBM forward to excavate the next section. The cutting head is subjected to a lot of wear and so its cutters need to be regularly sharpened. The cross passages, intended primarily for emergency evacuation, were all excavated by hand. Here the excavated profile was first stabilised with sprayed concrete before being fitted with steel liners. The spoil from all these operations was utilised at Stratford to raise the general ground level to enable the regeneration work to go ahead.

The geology of the London/Essex section is part of an old river valley, consisting of gravels, clay, Thanet sands and chalk. Stratford station was designed as a 'box' and constructed using diaphragm walling techniques. Because of ever rising ground water levels (0.7m per year) in this area, deep wells had to be drilled to prevent uplift on the box structure.

A 3km tunnel near Thurrock takes the line under the Thames. This was built using a total of seven TBMs working in highly fissured chalk containing flints, an extremely hard material. It was considered at the outset that this would be one of the most risky parts of the link to construct, however in the event it proved reasonably trouble free.

Tunnelling under the Kent North Downs (Bluebell Hill) was all in hard rock, and the cross-section is a single bore. This was excavated with a road-header using the New Austrian Tunnelling Method (NATM) which involves, among other things, putting on a sprayed-on concrete lining.

The line crosses the River Medway on a new bridge, positioned adjacent to two existing highway bridges, (see page 1). The profile and span of the new bridge is similar to the existing bridges to minimise the visual impact. The viaduct sections were constructed by the push-launch method, ie. constructed on land and jacked out onto the piers, while the main span used the balanced cantilever technique. Further east a new bridge at Tutt Hill was needed to take the line over the M20. Here the new bridge was constructed ‘off-line’ and jacked into position during a night-time possession.

Whereas the electrical system of the domestic line is third-rail 750 volt DC, HS1 is 25,000 volts AC throughout with an overhead catenary. All signalling is ‘in-cab’, controlled from the Ashford signalling centre. For much of its route in Kent the route follows the M20 corridor. At Lenham freight loops are provided, allowing slower freight traffic to be marshalled until train paths are available at night when passenger traffic has ceased.

Fastest travel times from London to Brussels are now 1hr 51 min, and to Paris 2hr 15 min. Trains from Ramsgate and Canterbury also now use part of the new network, giving much improved journey times for these destinations.

Archaeology and Heritage

We were shown slides of two archaeological sites that were uncovered during excavation work. The first was an Anglo-Saxon cemetery near Cuxton in Kent. This had first been discovered during the construction of the London to Chatham railway in the 1860s. It contained graves from the 6th to 7th centuries. Not far from there, under Bluebell Hill, they found postholes in the chalk, this being evidence of a Neolithic longhouse about 6000 years old. Although such longhouses are well documented in northern France this was reckoned to be the first one of its type found in Britain.

On the subject of heritage, in Mersham near Ashford a 15th century house known as Bridge House was on the centreline of the proposed line. Being of somewhat fragile construction it was decided that the only safe way to retain the integrity of the house was to move it bodily. A ring-beam was therefore cast under the foundations and four skidways put down. Bridge House was jacked up and slowly moved about 100 yards to its new location with no damage. Services were reconnected and the residents moved back in. A successful and relatively cheap answer to the problem.

The talk was well illustrated with slides, many showing methods of tunnelling and construction in particularly clear detail. We are grateful to Doug Irvine for a very informative lecture. □

News from Brooklands 2018	
Newly created learning area	
<p>Brooklands Aircraft Factory and Flight Shed Exhibitions Inside the reconstructed Bellman Hangar, we have created a brand-new experience for visitors: the Brooklands Aircraft Factory. The Factory Floor evokes an authentic factory atmosphere and is full of activities, enabling visitors to try out aircraft-building skills for themselves, drawing on the Brooklands spirit of experimentation and creating a learning experience that is unique in the UK. On the mezzanine level, learn about aircraft design before walking across to the Flight Shed. Inside this new building, completed aircraft are on display and include the Hawker Fury, Hunter and Harrier and Sopwith Camel. Amongst these are displays on pioneer pilots, radio and navigation equipment.</p>	
<p>Concorde at Brooklands offers scheduled ‘flights’ throughout the day: see, hear and feel Concorde blast along the runway, soar into the sky and accelerate to Mach 2 - twice the speed of sound. Re-live the excitement of the Supersonic Age in our 35-minute Concorde ‘Flight’ evoking emotional memories.</p>	

Regular Events 2018	
Every Day 10:00 to 17:00	Postal Museum and Mail Rail Open Timed ride on Mail Rail, visit the Exhibitions before or after your ride. Includes <i>Voices from the Deep</i> ; £17.05/£15.40; exhibitions only £11/£9.
until 31 Oct	Michelham Priory Watermill open most afternoons.
Tue/Wed/ Thu Afternoons	until the end of September Mapledurham Watermill and Tearoom is open for pre-booked guided tours only enquiries@mapledurhamwatermill.co.uk; 07843 742833
Reopened after major refurbish- ment	Eling Tide Mill: Visitor Centre & Mill Café; Mon - Sun; 10:00-17:00; £6.00/£4.00; Eling Lane, Totton, Hants SO40 9HF, 023 8086 9575
Open Daily	Didcot Railway Centre: non-running days: £6.50, £6.00.
Open 6 Days	Crofton Beam Engines: Engine House open 10:30-16:30 every day except Weds. Non-steaming £4.50/£4.00,
Museum Open Wed/ Thu/Sun	Bursledon Brickworks: 11:00-16:00; non-steam days museum only £5/£4,
Walk Sun/Mon 10:40 Wed 18:15	Brunel Museum Walk: meet at Bermondsey tube station and be guided to the Brunel Museum and below into the Grand Entrance Hall; late opening after Wednesday’s walk; no booking required; £10/£8.
Boat Trip Daily 10:40 except Mon	Brunel Museum Boat Trip: meet at Embankment tube station (not pier) for a boat trip on the Thames, then by train through the oldest tube tunnel in the world and descent into the underground chamber, Brunel Museum; no booking required; £10/£8 (transport extra).

Diary May 2018

- 1 Tue Crossness Engines: Guided Tour + tea and biscuits (Beam Engine House will not be open); 11:00-14:00; £6 plus booking; book online.
- 1 Tue IWA: Guided Towpath Walk along the Grand Union Canal - Uxbridge to Denham start 14:30 outside Uxbridge tube station (High Street exit); £10/£8; no prior booking required.
- 2 Wed Brooklands Museum: Technical Concorde Experience Flights - Extended tour of the aircraft, flight deck visits and more time in rear cabin exhibition+ tour of Concorde Simulator; £30.
- 2 Wed Docklands History Group: The Story of an East End Family at War talk by Jane Cox; 18:00; £2 donation.
- 3 Thu London Canal Museum: The New River talk by Richard Thomas.
- 3 Thu Mapping the Mills: Explore the Industrial Heritage of the River Wandle - Walk 3 - High Street Carshalton to Hackbridge, celebrating the power of water within the historic industries of the River Wandle; meet 10:30 outside the Coach and Horses pub, 12 High Street, (Carshalton Station, Buses. 127, 1 57, 407, X26), end about 12:00: Hackbridge, Hackbridge Road, SM5 2DD (Hackbridge Station).
- 5 Sat Gatwick Aviation Museum: Fast Jets day.
- 5 Sat Brooklands Museum: Auto Italia Italian Car Day One – see them blast up Test Hill, 10:00-17:00; £13.50/£11.50.
- 5 Sat IWA Canalway Cavalcade: - London's biggest, brightest and best waterways festival, Little Venice since 1983.
- 5 Sat STEAM: Meet the Railway Workers.
- 5 Sat Museum of London Docklands: Docklands Regeneration + Crossrail; walking tour at 14:00; £12.50; book www.museumoflondon.org.uk/museum-london-docklands
- 5 Sat – 7 Mon Didcot Railway Centre: Steam Days.
- 5 Sat – 7 Mon Crofton Beam Engines: Bank Holiday Steaming; £8/£7.
- 5 Sat - 6 Mon Chatham Historic Dockyard: Railway Weekend.
- 6 Sun Twyford Waterworks: Spring Rally. Open Day (11:00-16:00); £7/£6.
- 6 Sun Amberley Museum & Heritage Centre: Classic Motorcycles Day 10:00-17:00.
- 6 Sun Kirkaldy Testing Museum: Open Day. 11:00-17:00; 99 Southwark Street, SE1 0JF; www.testingmuseum.org.uk/opening.html.
- 6 Sun IWA: Guided Waterside Walk - River Tyburn, and along Regent's Canal to Little Venice start 14:30 outside Baker St tube station (Baker St north/Lords exit); £10/£8; no prior booking required.
- 7 Mon Brooklands Museum: Emergency Services Day.
- 7 Mon Twyford Waterworks: Travel by Friends of King Alfred Buses vintage bus and get in free with FoKAB programme; www.fokab.org.uk.

Venues, Times & Contacts are on page 3.

Diary May 2018

- 9 Wed Newcomen London: Dickinson Memorial Lecture - Measuring Greatness: Engineering Biography- Scholarship, Hagiography or a Marketing Tool? talk by Mike Chrimes.
- 9 Wed Inland Waterways Association: Magical Lantern Show by Aileen Butler; 20:00 in the Primary Room at the United Reformed Church Hall, Addiscombe Grove, Croydon CR0 5LP. Suggested donation £2.
- 10 Thu London Canal Museum Tunnel Boat Trips: through Islington tunnel from the museum; return trip about 50 minutes; departure 11:30, 12:30 14:00 and 15:00; £9 including museum entry; book online.
- 10 Thu Mapping the Mills: Walk 4 - Morden Hall Park to Colliers Wood - how industries used the Wandle; meet 10:30 at Morden Hall Snuff Mills, Morden Hall Park, Morden Hall Road, SM4 5JD and end 12:00 at Merton High Street, Colliers Wood, SW19 1DD (Colliers Wood Underground Station, Buses: 57, 1 31 , 1 52, 200, 21 0, 470); book with Katie Russell, 020 7608 0775, katie@buildingexploratory.org.uk.
- 12 Sat Docklands History Group Conference: Shipbuilding on the Thames see page 3.
- 12 Sat Brixton Windmill: Booking is required for full tours on the hour and half hour from 13:00 to 16:30, a tour lasts about 40 minutes. Booking is not required for short tours.
- 12 Sat - 13 Sun National Mills Weekend
- 12 Sat Gatwick Aviation Museum: Aerojumble.
- 12 Sat - 13 Sun Didcot Railway Centre: Heritage Diesel Days Board the Diesel Railcar for a 1940s ride.
- 12 Sat - 13 Sun Ancient Technology Centre: 10:00-16:00 £5.00, pay on the day.
- 12 Sat Amberley Museum & Heritage Centre: Minis at the Quarry.
- 13 Sun Shalford Mill: open for National Mills weekend 11:00-16:15.
- 13 Sun London Canal Museum Tunnel Boat Trips: through Islington tunnel from the museum. The guided return trip lasts about 50 minutes; departure 11:00, 12:00, 14:00 ,15:00, 16:00; £9 incl museum entry; book online.
- 13 Sun Amberley Museum & Heritage Centre: Commercial Vehicles Day.
- 13 Sun Amberley Museum & Heritage Centre: Commercial Vehicles Day.
- 14 Mon Hampshire IAS: Swaythling Remount Depot Supplying Horses for War Service talk by John Fish.
- 14 Mon - 20 Sun Assn for Industrial Archaeology: Spring Tour – Saxony see page 3.

Diary May 2018

- 19 Sat - 19 Sun Rural Life Centre:
Double LL Club meeting.
- 19 Sat STEAM: Meet the Railway Workers.
- 19 Sat Royal Gunpowder Mills:
Walking tours; £10-50/£9; Beaulieu Drive,
Waltham Abbey, Essex EN9 1JY.
- 19 Sat - 20 Sun Kempton Steam Museum: Stationary
Engine Running Weekend; Triple in steam
and railway running both days.
- 19 Sat Didcot Railway Centre~ Heritage Diesel Day,
Diesel Railcar for 1940s ride.
- 19 Sat Royal Gunpowder Mills
Waltham Abbey: Walking Tour;
book: [www.invitationtoview.co.uk/
properties/royal-gunpowder-mills/](http://www.invitationtoview.co.uk/properties/royal-gunpowder-mills/).
- 19 Sat Friends of Nunhead Cemetery
Nunhead. Open Day. 11:00-17:00.
- 20 Sun Crossness Engines: Family Open Day -
Non Steaming; Beam Engine House will not
be open; an exhibition, a display of smaller
engines, activities for children and the building
itself, at least from the outside; 10:30-16:00;
no booking required - just turn up; £4.
- 20 Sun IWA: Guided Towpath Walk along the Grand
Union Canal: Uxbridge to Denham start 14:30
outside Uxbridge tube station (High Street
exit); no prior booking required.
- 21 Mon Berkshire IAG: 125 Years of Raleigh Bicycles
talk by Tony Hadland.
- 24 Thu London Canal Museum:
Tunnel Boat Trips see 10 May.
- 26 Sat - Sun 3 June London Museum of Water &
Steam: Live Steam Model Railway weekend.
- 26 Sat - 28 Mon Didcot Railway Centre:
Rails on the Western Front.
- 26 Sat - 28 Mon Crofton Beam Engines:
Late May Bank Holiday Steaming.
- 27 Sun Rural Life Centre: Bus & Coach Rally -
vintage vehicles on parade, some taking visitors
for a nostalgic ride through the local lanes.
- 27 Sun Brooklands Museum: MOPAR Muscle Associ-
ation event.
- 27 Sun London Canal Museum:
Tunnel Boat Trips see 13 May.
- 27 Sun - 28 Mon Chatham Historic Dockyard:
Railway Weekend.
- 31 Thu London Canal Museum: London History Day -
Guided Canal History Walk from the museum
to Camden Town; £7.50/£6 including museum
entry beforehand; departs at 15:00 and arrives
at Camden Town at approx 16:30; book online.

Diary June 2018

- 1 Fri Guildford Museum:
Tunsgate: Two Centuries and More of Change
talk by Hugh Anscombe, Town Guide;
supporting our exhibition Tunsgate - a century of
change; at Victorian Playroom,
39½ Castle Street, Guildford; 12:00;
free; please book at 01483 444751.
- 2 Sat STEAM: Meet the Railway Workers.
- 2 Sat - 3 Sun Didcot Railway Centre Steam Days.
- 3 Sun Twyford Waterworks: Running Days;
ex-industrial petrol, diesel and battery electric
locomotives on both our short lines; please note:
we do not give rides on any of our railways.
- 3 Sun Museum of London Docklands:
Docklands Regeneration, including the Crossrail
project; walking tour starting at 14:00; £12.50;
book online - [www.museumoflondon.org.uk/
museum-london-docklands](http://www.museumoflondon.org.uk/museum-london-docklands).
- 3 Sun Amberley Museum & Heritage Centre:
London to Brighton Classic Car Run.
- 3 Sun Kirkaldy Testing Museum: Open Day;
11:00-17:00; 99 Southwark Street, SE1 0JF;
www.testingmuseum.org.uk/opening.html.
- 3 Sun IWA: Guided Waterside Walk - Limehouse,
Thames, & Docklands; start: at 14:30, outside
Westferry DLR station (by the Cycle Hire Point);
£10/£8; no prior booking required.
- 4 Mon - 8 Fri Country House Comfort & Convenience -
E Yorkshire see page 7.
- 4 Mon Hampshire IAS:
Silk Stockings and Spitfires talk by John Smith.
- 6 Wed Docklands History Group: DP World London
Gateway deep-sea container terminal talk
by Matt Abbott, Communications Manager.
- 7 Thu Subterranea Britannica: Paddock (Alternative
Cabinet War Room) Open Day; Brook Road
Dollis Hill, London, NW2, OS TQ223863.
- 7 Thu London Canal Museum:
The East End's Canals - Local Voices talk
by Carolyn Clark, Community Historian.
- 9 Sat - 10 Sun Gatwick Aviation Museum:
Horsham Historics - Props and Shafts.
- 9 Sat - 10 Sun Didcot Railway Centre: Steam Days.
- 9 Sat -10 Sun Amberley Museum & Heritage Centre:
Mid-Summer Steam Show.
- 9 Sat -10 Sun London Parks and Gardens Trust:
Open Garden Squares Weekend; details -
www.opensquares.org.
- 10 Sun London Canal Museum:
Tunnel Boat Trips see 13 May.
- 12 Tue Brooklands Museum: Technical Concorde Expe-
rience Flights - extended tour of the aircraft,
flight deck visits and more time in rear cabin
exhibition + Tour of Concorde Simulator. £30.

Venues, Times & Contacts are on page 3.

Recording Factory Closures

A good opportunity to record the history & to rescue
traditional papers & machinery! *If you hear of a factory
which is about to close,
please report it to us; contacts on page 13.*

Diary June 2018

- 12 Tue Crossness Engines: Guided Tour, see 1 May.
- 13 Wed IWA: Heroes and Villains of the Basingstoke Canal talk by Roger Cansdale; 20:00; Primary Room, United Reformed Church Hall, Addiscombe Grove, Croydon CR0 5LP; £2 donation.
- 14 Thu London Canal Museum: Tunnel Boat Trips see 10 May.
- 15 Fri 16 Sat Portsmouth Historic Dockyard: Conference - Silent and Secret see page 3.
- 16 Sat STEAM Meet the Railway Workers.
- 16 Sat Didcot Railway Centre: Steam Day.
- 16 Sat IWA: Guided Towpath Walk along the Regent's Canal: Little Venice to Camden; start at 10:45 outside Warwick Avenue tube station.
- 16 Sat - 17 Sun Kempton Steam Museum: Steaming Weekend - Father's Day - Triple & railway running both days.
- 17 Sun Didcot Railway Centre: Father's Day Steam train rides on the Main Demonstration Line.
- 17 Sun Crossness Engines: Family Open Day – Non-Steam, see 20 May.
- 17 Sun IWA: Guided Waterside Walk along the Grand Surrey Canal, to Royal Navy Victualing Yard, then Thames Path and Greenland Dock; start at 14:30 outside Surrey Quays Station (Overground).
- 20 Wed Holmesdale Natural History Club: The Birth, Life and Death of the River Mole talk by Prof. Richard Selley; 20:00; The Museum, 14 Croydon Road, Reigate, Surrey RH2 0PG.
- 20 Wed Peckham Society: Walk - Peckham Rye Park to One Tree Hill; 18:30-20:30; meet at The Clock House, East Dulwich; www.peckhamsociety.org.uk.
- 21 Thu - 24 Sun Railway and Canal Historical Society Conference see page 3.
- 23 Sat Royal Gunpowder Mills: Walking Tours; book at www.invitationtoview.co.uk/properties/royal-gunpowder-mills/.
- 23 Sat - Sun 24 Didcot Railway Centre: Opening of The Signalling Centre + Trains in Operation.
- 23 Sat - Sun 24 Crofton Beam Engines: Steaming Weekend.
- 23 Sat - Sun 24 Amberley Museum & Heritage Centre: Emergency Services Weekend.
- 24 Sun Brooklands Museum - London Bus Museum: Summer Event.
- 24 Sun London Canal Museum: Tunnel Boat Trips see 13 May.
- 28 Thu London Canal Museum: Tunnel Boat Trips see 10 May.
- 30 Sat - Sunday 4 July Brewery History Society: AGM & visits see page 3.
- 30 Sat Gatwick Aviation Museum: Armed Forces Day.
- 30 Sat Didcot Railway Centre: Steam Day.

Diary July 2018

- 1 Sun Rural Life Centre: Car Boot Sale organised by the Rustics; 08:00-12:00.
- 1 Sun Rural Life Centre: Prefab Exhibition - Elisabeth Blanchet will host a tea party to explore the social history of prefab buildings through objects, photographs, film and sound recordings.
- 1 Sun Brooklands Museum: The Brooklands Motorcycle Show.
- 1 Sun Twyford Waterworks: Open Day.
- 1 Sun Didcot Railway Centre: Steam Day.
- 1 Sun IWA: Guided Towpath Walk along the Regent's Canal: Islington to Mile End; start: at 14:30 outside Angel tube station.
- 2 Mon Hampshire IAS: Women on the Railway talk by Becky Peacock.
- 4 Wed Docklands History Group: AGM + The Thames Fisheries talk by Roger Williams.
- 5 Thu London Canal Museum: Freight on Waterways talk by John Pomfret; 19:30.
- 7 Sat - 8 Sun Rural Life Centre: Fire Engines on Show - a fire engine festival.
- 7 Sat Museum of London Docklands; Docklands Regeneration and Crossrail Walking Tour; £12.50; book online at www.museumoflondon.org.uk/museum-london-docklands.
- 7 Sat Gatwick Aviation Museum: Shackleton engine run.
- 7 Sat Didcot Railway Centre: Steam Day.
- 8 Sun London Canal Museum: Tunnel Boat Trips see 13 May.
- 12 Thu London Canal Museum: Tunnel Boat Trips see 10 May.
- 13 Fri - 17 Tue Newcomen Society: Annual Conference & Tour see page 3
- 14 Sat STEAM: Meet the Railway Workers.
- 14 Sat Wealden Iron Research Group: Summer Meeting and AGM; Lewes Town Hall. Lecture Room, High St, Lewes, E Sussex, BN7 2QS; 11:00: Iron Production in the pre-Roman and Roman Weald presentation by our sponsored research student Ethan Greenwood; then a visit to Anne of Cleves House (including the Iron gallery) at 52, Southover High St, Lewes, BN7 1JA; 14:00.
- 14 Sat STEAM: Meet the Railway Workers.
- 14 Sat - 15 Sun Didcot Railway Centre: Star Tugs Weekend, Steam Trains in Operation.
- 14 Sat - 15 Sun Amberley Museum & Heritage Centre: Rail Gala.
- 14 Sat IWA: Guided Towpath Walk along the Regent's Canal: King's Cross – Granary Square - Camden start at 10:45, outside King's Cross tube station (taxi rank).
- 15 Sun IWA: Guided Towpath Walk along the Regent's Canal: Little Venice to Camden start at 14:30 outside Warwick Avenue tube station.

Venues, Times & Contacts are on page 3.

Diary July 2018

- 15 Sun Crossness Engines: Family Open Day - Non Steaming see 20 May.
- 21 Sat - 22 Sun Weald and Downland Open Air Museum: Working Animals; 10:30-17:00.
- 21 Sat Brewery History Society: Brewing in Oxford- A Two-Hour Walking Tour starting 13:30 at Oxford Railway Station led by local historian Liz Woolley (<http://lizwoolley.co.uk/guided-walks>); £6 plus charge for a visit to the former brewhouse of an Oxford college; please contact Mick Connors at m.p.connors@btinternet.com to register or for further information.
- 21 Sat Royal Gunpowder Mills: Walking tours; £10-50/£9; Beaulieu Drive, Waltham Abbey, Essex, EN9 1JY; booking at www.invitationtoview.co.uk/properties/royal-gunpowder-mills/.
- 21 Sat - 22 Sun Didcot Railway Centre: Steam Days.
- 22 Sun Rural Life Centre: Ford MKII Car Rally; all classic cars are welcome.
- 22 Sun Brooklands Museum: Retro Jumble and Classic Car Show.
- 22 Sun London Canal Museum: Tunnel Boat Trips see 13 May.
- 22 Sun Bursledon Brickworks: Trains at the Brickworks - Steam-up.

Diary July 2018

- 24 Tue Crossness Engines: Guided Tour see 1 May.
- 24 Wed Didcot Railway Centre: Steam Day.
- 26 Thu London Canal Museum: Tunnel Boat Trips see 10 May.
- 28 Sat Brooklands Museum: Supercar Saturday.
- 28 Sat

Surrey Industrial History Group: AGM and Conservation Award at Shere Village Hall and Museum; see pages 14 & 15 .
- 28 Sat STEAM: Meet the Railway Workers.
- 28 Sat - 29 Sun Gatwick Aviation Museum: Medieval Weekend.
- 28 Sat - 29 Sun Didcot Railway Centre: Steam Days.
- 28 Sat - 29 Sun Crofton Beam Engines: Steaming Weekend.
- 29 Sun

Rural Life Centre: Rustic Sunday
The biggest annual event of the year, try out traditional crafts, ride on the steam train and see a working steam roller; watch the working blacksmith in the museum's smithy; the reconstructed iron furnace and the wood yard will both be in action.
- 29 Sun Amberley Museum & Heritage Centre: Classic Car Summer Show.

Venues, Times & Contacts are on page 3.

The deadline for **submitting copy** for the next Newsletter is
12 July 2018

*Submissions are accepted in typescript, on a disc, or by email to news@sihg.org.uk.
Anything related to IA will be considered. Priority will be given to Surrey-based or topical articles.
Contributions will be published as soon as space is available.
Readers are advised that the views of contributors are not necessarily the views of SIHG.*

Website: www.sihg.org.uk

The SIHG Newsletter is now issued quarterly, covering:

<i>February</i>	<i>May</i>	<i>August</i>	<i>November</i>
<i>March</i>	<i>June</i>	<i>September</i>	<i>December</i>
<i>April</i>	<i>July</i>	<i>October</i>	<i>January</i>

Published by Surrey Industrial History Group,
printed by YesPrint 3 Leafy Oak Workshops Cobbetts Lane Yateley GU17 9LW
© SIHG 2018 ISSN 1355-8188

SIHG is a group of the Surrey Archaeological Society,
Registered Charity No 272098 - Castle Arch Guildford Surrey GU1 3SX
Group President: Prof AG Crocker FSA

Surrey Industrial History Group Officers

Chairman & Lectures Organiser: **Robert Bryson** 6 Wychelm Rise Guildford Surrey GU1 3TH 01483 577809 meetings@sihg.org.uk
Secretary: **Hugh Anscombe** Hollybush Cottage Colmans Hill Peaslake Guildford Surrey GU5 9ST 01306 731406 info@sihg.org.uk
Treasurer & Sales: (vacant) Acting Treasurer: **Robert Bryson** treasurer@sihg.org.uk
Vice Chairman & Membership Secretary: **Pam Taylor** 36 Brooklands Road Farnham Surrey GU9 9BS 01252 715218 membership@sihg.org.uk
Newsletter Editor: **Jan Spencer** 16 The Park Bookham Leatherhead Surrey KT23 3JL 01372 454766 news@sihg.org.uk

Surrey Industrial History Group

Annual General Meeting: 2:00 pm on 28 July 2018
at Shere Village Hall, Shere, Surrey

Joining Instructions



Shere Museum

Shere Village Hall

The AGM will be held at Shere Village Hall in Shere.

Shere Museum and Village Hall are on the north side of Gomshall Lane, very close to the bus stop on that side of the road. Turn off into Shere from the A25 and look for somewhere to park. If you are coming from the south along Middle Street in Shere you will reach a T junction: turn right into Gomshall Lane and the Museum and Hall are a very short distance on your left, but you will be unable to park there. If you turn left at the same T junction coming from the south there is a car park after 30 yards on your right. There is usually parking along Gomshall Lane as well. There will be an opportunity to view

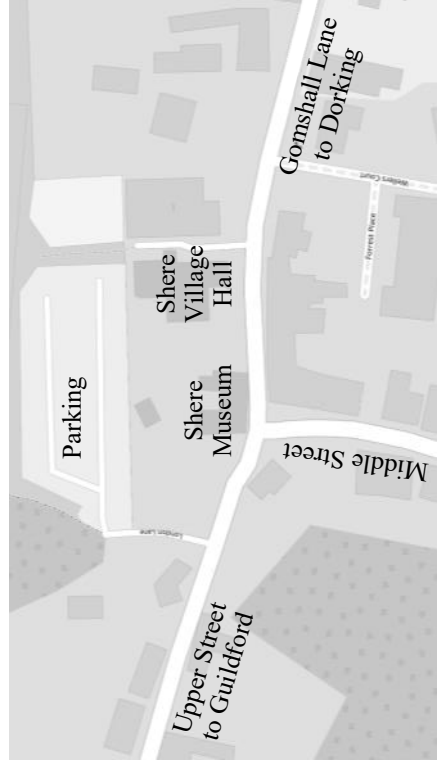

SURREY ARCHAEOLOGICAL SOCIETY

SURREY INDUSTRIAL HISTORY GROUP (SIHG)

MINUTES OF THE ANNUAL GENERAL MEETING
HELD AT THE RURAL LIFE CENTRE
ON SATURDAY 15th JULY 2017

Present: Alan Crocker, Bob Bryson (Chairman), Celia Gregory, Glenys Crocker, Hugh Ancombe (Secretary), John Bourne, Pam Taylor (Vice-Chairman and Membership Secretary), Norma Cox, Peter Minetti, Roy Johnson, Susan Bourne.

Apologies for Absence: Gerry Moss, Jan Spencer (Newsletter Editor), Margaret Levett.

Corrections to the AGM Minutes of 9 July 2016: No corrections required.

Chairman's Report: The chairman's report had previously been circulated to members in the Newsletter. Roy Johnson asked about the advertising for the Guildford lectures and Bob Bryson replied that 750 leaflets had been circulated to local libraries. Bob also asked members to send him ideas for publicising the lecture series such as local free magazines (Vantage Point et al.)

Alan Crocker said that it was a shame that we had no ongoing industrial history or industrial archaeology projects for young people to get involved with. There was general agreement about this.

Treasurer's Report: The Stuart Chrystall charity (COIF) account has been merged with another COIF account but the Stuart Chrystall bequest is intact: in fact Stuart Chrystall bequest amounts have in the past been paid from other accounts because these accounts paid lower interest than the Stuart Chrystall account.

Bob Bryson pointed out that the £392 shown as AGM expenses in the accounts is in fact the cost of three plaques for future use as Conservation Awards.

The value of the group is very healthy at £39,460 as at 31st March 2017. This is invested in financial assets and no additional value is attributed to the stocks of books, plaques, goodwill or etc.

An amount for gift aid has been allocated to SIHG in the Surrey Archaeological Society Accounts but as it has not yet been received by SIHG it is not yet in the SIHG accounts.

Re-election of Officers and Committee:

The following elections and re-elections took place:

Chairman	Robert Bryson
Vice-Chairman	Pam Taylor
Secretary	Hugh Ancombe
Newsletter Editor	Jan Spencer
Committee	Margaret Levett
Committee	Gerry Moss

SURREY ARCHAEOLOGICAL SOCIETY

SURREY INDUSTRIAL HISTORY GROUP (SIHG)

MINUTES OF THE ANNUAL GENERAL MEETING
HELD AT THE RURAL LIFE CENTRE
ON SATURDAY 15th JULY 2017

Present: Alan Crocker, Bob Bryson (Chairman), Celia Gregory, Glenys Crocker, Hugh Ancombe (Secretary), John Bourne, Pam Taylor (Vice-Chairman and Membership Secretary), Norma Cox, Peter Minetti, Roy Johnson, Susan Bourne.

Apologies for Absence: Gerry Moss, Jan Spencer (Newsletter Editor), Margaret Levett.

Corrections to the AGM Minutes of 9 July 2016: No corrections required.

Chairman's Report: The chairman's report had previously been circulated to members in the Newsletter. Roy Johnson asked about the advertising for the Guildford lectures and Bob Bryson replied that 750 leaflets had been circulated to local libraries. Bob also asked members to send him ideas for publicising the lecture series such as local free magazines (Vantage Point et al.)

Alan Crocker said that it was a shame that we had no ongoing industrial history or industrial archaeology projects for young people to get involved with. There was general agreement about this.

Treasurer's Report: The Stuart Chrystall charity (COIF) account has been merged with another COIF account but the Stuart Chrystall bequest is intact: in fact Stuart Chrystall bequest amounts have in the past been paid from other accounts because these accounts paid lower interest than the Stuart Chrystall account.

Bob Bryson pointed out that the £392 shown as AGM expenses in the accounts is in fact the cost of three plaques for future use as Conservation Awards.

The value of the group is very healthy at £39,460 as at 31st March 2017. This is invested in financial assets and no additional value is attributed to the stocks of books, plaques, goodwill or etc.

An amount for gift aid has been allocated to SIHG in the Surrey Archaeological Society Accounts but as it has not yet been received by SIHG it is not yet in the SIHG accounts.

Re-election of Officers and Committee:

The following elections and re-elections took place:

Chairman	Robert Bryson
Vice-Chairman	Pam Taylor
Secretary	Hugh Ancombe
Newsletter Editor	Jan Spencer
Committee	Margaret Levett
Committee	Gerry Moss

Surrey Industrial History Group (SIHG)

A Group of the Surrey Archaeological Society
(Registered Charity No. 272098)

**Annual General Meeting: 2:00 pm on 28 July 2018
at Shere Village Hall, Shere, Surrey**

Agenda

- 1. Apologies for Absence**
- 2. Minutes of the Annual General Meeting of 15 July 2017**
- 3. Chairman's Report for the year ending 31 March 2018**
- 4. Treasurer's Report for the year ending 31 March 2018**

5. Committee Nominations for Elections

Chairman	Robert Bryson
Vice-Chairman	Pam Taylor
Secretary	Hugh Anscombe
Treasurer	vacant
Newsletter Editor	Jan Spencer

Pam Taylor retires in rotation after three years' service.
She offers herself for re-election and is nominated by the Committee.

Other nominations for Officers or Committee Members are invited, and should be sent to the Secretary not later than 25 June 2018, and must bear the names of the proposer and second and the signature of the nominee indicating willingness to serve.

6. Any other business

Any resolution proposed under this heading should be notified to the Secretary not later than 2 July 2018.

Hugh Anscombe
Honorary Secretary

After the AGM we shall present the 2018 SIHG Conservation Award to Shere Museum and the Surrey Hills Society jointly. The Museum has an interesting display of local artefacts and now hosts a gallery dedicated to the Tillingbourne Tales Project, which has been organized by the Surrey Hills Society. SIHG will also make a donation to each partner in recognition of their achievements."

Surrey Industrial History Group Chairman's Report for the year ending 31 March 2018

This is my thirteenth annual report (unlucky for some) as Chairman of the Surrey Industrial History Group. The first event of the year was, as usual, the South East Region Industrial Archaeology Conference. This year the event was hosted by the Sussex Industrial Archaeology Society and held at Worthing College on 22 April 2017.

Our AGM was held on 15 July at the Rural Life Centre in Tilford, when Vice Chairman Pam Taylor presented Norman Emblow with the 2018 Conservation Award. Norman was responsible for leading the project to dismantle Deek's Frimley Green Cycle Workshop, which ceased trading in 2002, and having the building and contents transferred to the Rural Life Centre.

The 42nd series of Industrial Archaeology Lectures held in Guildford commenced on 10 October with a lecture on the R101 Airship by Dr Bryan Lawton of the Newcomen Society and concluded on 5th March with a talk on the preservation of the SS Shieldhall by her Chief Engineer Graham Mackenzie.

The Thursday morning weekly talks at the Institute in Leatherhead were again organised by Margaret Levett who arranged the speakers and John Bourne who chaired the meetings. The talks, held over both the autumn and spring terms, commenced on 5 October with a talk by James Preston on airports in Kent that were proposed but not developed. On 15 March Richard Savage gave the last lecture in the series to the Leatherhead group on Alexander Raby and Downside Mill. The final meeting at Leatherhead, held on 22 March, was open to various talks given by the members.

Membership of the group at the last count was 95, made up of 79 ordinary members, 6 Associate, 7 Institutional and 3 honorary; a further eight down on last year; however a couple of members have since renewed their subscriptions.

Our Newsletter and website www.sihg.org.uk continue to be the best source for up to date information on group activity and I would like to thank all the members of SIHG, especially my fellow committee members, who have supported the work of the group throughout the year.

Bob Bryson
Chairman